

**Digital depth table**

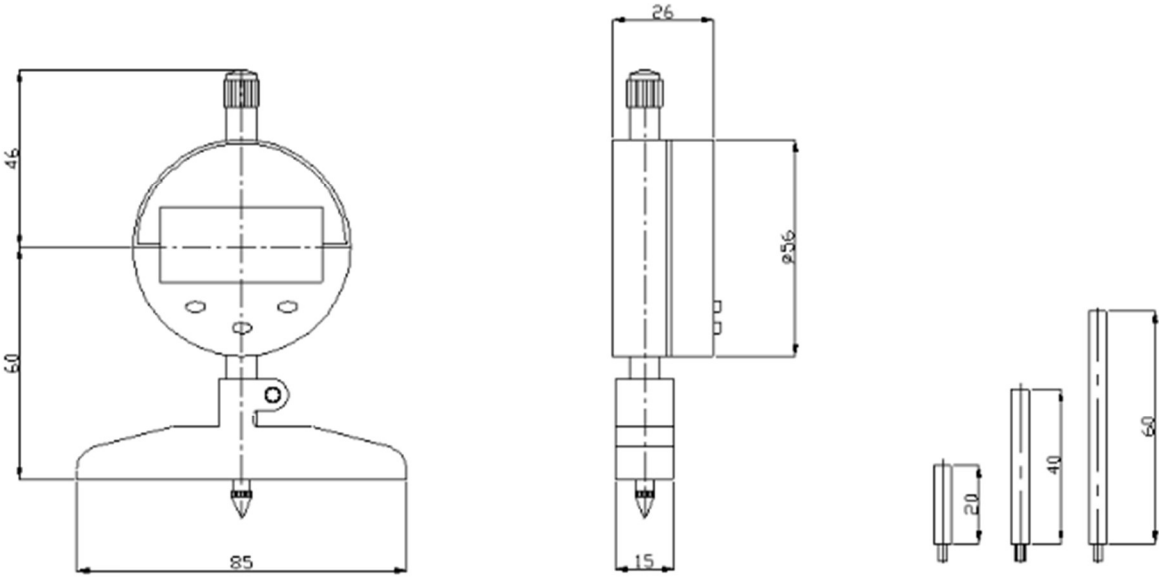

**PRODUCT DESCRIPTION**



**1. Carbide probe, stainless steel base, compact and firm structure, easy operation, stable work**

**2. Clear at any position**

**3. Metric and English conversion**

**4. It can be used to measure the size of the inner hole of the workpiece, the depth of the groove and the height of the step**

Measuring range Measuring Range mm	Resolution Resolution mm / inch	Allowable error Permissible Error mm
0-100	0.01 / .0005 "	± 0.03